



Power Range	kW	kVA
Standby	40.0	40.0
Prime	36.4	36.4

MODEL: HYW - 45 M6

STANDARD EQUIPMENT

Open Type Set	Accessories Available for HYW-45 M6
<ul style="list-style-type: none"> ■ Skid with integral day fuel tank (non-UL) ■ HIPOWER digital auto-start control panel (Page 4) ■ Dry-type replaceable element air-cleaner ■ Industrial muffler ■ Battery, battery rack, and cables ■ Fuel and lubrication oil replaceable element filters ■ Stamford AVR brushless 12-wire reconnectable alternator ■ Oil drain hand pump ■ Vibration Isolators between base and set assembly ■ Main Line Circuit Breaker for overload protection ■ Belt driven charging alternator ■ Guards for shielding all rotating parts ■ Fuel cut-off solenoid and protection switches ■ Radiator with pusher fan ■ Operation and installation manuals 	<p style="text-align: center;"><u>Mechanical Accessories Offered</u></p> <ul style="list-style-type: none"> ■ Road towing trailers to DOT standards ■ Critical grade exhaust mufflers ■ UL double wall fuel tanks to customer specification ■ Oil field type skid ■ Flexible exhaust connection for open sets ■ Oil pressure and engine temperature gauges ■ Water Jacket heater ■ Extended warranty coverage period <p style="text-align: center;"><u>Generator End Accessories Offered</u></p> <ul style="list-style-type: none"> ■ Anti-condensation heaters in alternator <p style="text-align: center;"><u>Electrical and Control Accessories Offered</u></p> <ul style="list-style-type: none"> ■ Automatic battery chargers 1.5 and 6 amp ■ NFPA 110 controls and remote annunciator ■ Transfer switch and paralleling control panels ■ Remote control from PC via hard and/or wireless link ■ Digital Timer
<p style="text-align: center;">Sound Attenuated Enclosure</p> <ul style="list-style-type: none"> ■ Fully sound attenuated enclosure (equipped as open set) ■ Powder Painted with finish that exceeds 1000-hr salt test ■ Rock wool insulation behind protective barrier ■ Curved edges and minimum outside fasteners ■ Single lifting point 	

GENERATOR RATINGS

Alternator	Voltage	Ph	Hz	Standby Rating		Prime Rating	
				kW/kVA	Amps	kW/kVA	Amps
BCI 184J Wdng 06	120 / 240	1	60	40.0 / 40.0	166	36.4 / 36.4	152

Application Data

Alternator Specifications		Engine Mechanical Specifications	
Manufacturer	Newage Stamford	Manufacturer	Yanmar
Type	4-pole, rotating field	Engine model	4TNV98T
Exciter type	Brushless, self excited.	Engine type	4-cycle, Turbocharged
Leads: quantity, type	12, reconnectable	Cylinder arrangement	4 in line
Voltage regulator	Solid state, volts/Hz and excitation overload protection	EPA Certification :	TIER 3
Insulation:		Displacement, L (cu. in.)	3.32 (203)
Material.....	Class H	Bore and stroke, mm (in.)	98 x 110 (3.86 x 4.33)
Temperature rise.....	150° C , standby	Compression ratio	18.1 : 1
Bearing: quantity, type	Single bearing sealed	Piston speed, m/min. (ft./min.)	395.9 (1299)
Coupling	Flexible disc	Main bearings: quantity, type	5, replaceable insert
Amortisseur Windings	Full	Rated rpm	1,800
Voltage regulation, no-load to full load	± 1.5%	Max. power at rated rpm, kWm (BHP)	51.0 (68.4)
Unbalanced load capability	100% of rated standby current	BMEP, gross, psi (Bar)	148.5 (10.24)
Load acceptance	Per ISO - 8528	Overall thermal efficiency	35.4%
Peak motor starting kVA: 480 V 480 V	(30% dip) self-excited series - 100 kVA	Exhaust Gas Flow, m ³ /min (cfm)	15.0 (530.3)
Engine Electrical Specifications		Exhaust gas temperature °C (°F)	580 (1076)
		Frequency regulation, no-load to full load	4.5 %
Engine Electrical System (12 Volt) 60 Hz		Governor: Type:	Mechanical
Battery charging alternator:		Make:	Yanmar
Ground (negative/positive).	Negative	Standard:	
Volts (DC).....	12V	Frequency regulation, steady state	±4.5%
Ampere rating.....	40A	Frequency	Fixed
Starter motor rated voltage (DC)	12V	Air cleaner type	Dry
Starter motor rated kW:	2.3Kw	Remote Radiator System	
Battery CCA rating:	770A	Fuel Consumption 60 Hz	
Battery & qty, AH rating:	1 x 70 AH	Diesel gal/hr (L/hr) Standby Rating	
Battery Voltage (DC)	12V	100% 3.79 (14.3)	
Not Available		75% 3.03 (11.5)	
		50% 2.27 (8.6)	
		25% 1.33 (5.0)	
		Diesel gal/hr (L/hr) Prime Power Rating	
		100% 3.43 (13.0)	
		75% 2.74 (10.4)	
		50% 2.06 (7.8)	
		25% 1.20 (4.5)	
Contact the HIPOWER distributor for special cooling options			

Application Data

Cooling		Lubrication	
Radiator Systems	60 Hz	Lubricating System	60 Hz
Ambient temperature, °C (°F)	NA	Type	Full pressure
Engine jacket water capacity L (gal)	4.2 (1.1)	Oil pan capacity, L, (qt.)	10.5 (11.1)
Radiator system capacity, including engine, L (gal.)	NA	Recommended lube oil	SAE15W40 ; API CF-4
Engine jacket water flow, L/min (g/min)	50 (13.2)	Oil pan capacity with filter, L (qt.)	NA
Heat rejected to cooling water at rated kW, dry exhaust, kW (Btu/min.)	35.0 (1991)	Oil filter: quantity, type	1, cartridge
Water pump type	Centrifugal	Oil cooler	Oil to water
Fan, kWm (HP)	0.6 (0.8)	Maximum oil temperature, °C(°F)	120 (248)
Max. restriction of cooling air, intake and discharge side of radiator, Pa (in. H ² O)	62.2 (0.25)	Ventilation and Air-Flow Requirements	
dB(A) LEVEL SOUND ATTENUATED ENCLOSED	63 dB(A) @ 23 feet	Air Requirements	60 Hz
		Radiator-cooled cooling air, m ³ /min. (scfm)	NA
		Air density kg/m ³ (ibm/ft ³)	1.20 (0.075)
		Heat rejected to exhaust, kW (btu/min)	47.4 (2696)
		Heat radiated to surrounding air Engine: kW (Btu)	9.5 (540)
		Combustion air, m ³ /min. (cfm)	3.88 (137.4)

Dimensions and Weights

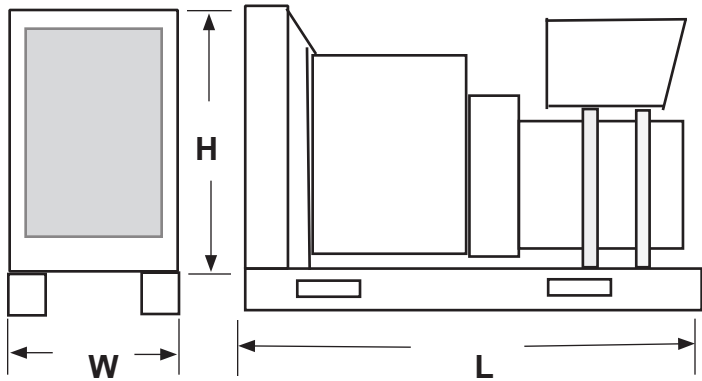
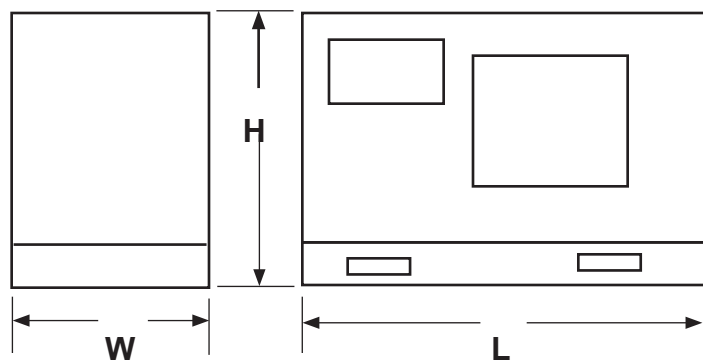
Open Skid Model		Sound Attenuated Enclosure	
Overall size, L x W x H, mm (ins.)	1,950 x 780 x 1,280 (76.8 x 30.7 x 50.4)	Overall size, L x W x H, mm (ins.)	2,250 x 1,100 x 1,340 (88.6 x 43.3 x 52.8)
Weight, radiator-mounted model, wet, kg (lb.):	702 (1,548)	Weight, radiator-mounted model, kg (lb.):	1,140 (2,513)
Fuel Tank Capacity, L (US gal)	91 (24.8)	Fuel Tank Capacity, L (US gal)	100 (26.4)
			

NOTE: The drawings above are only representative of the overall dimensions. For full detailed installation drawings please consult your local distributor or contact Himoina Power Systems @ www.hipowersystems.com

RATINGS: Power factor three-phase is 0.8 and single-phase unity. Standby Ratings: Standby ratings assume installation normally served by reliable utility power. The standby rating is available for varying loads for the length of the power outage. No overload is available with the standby rating. Ratings are in accordance with ISO-3046/1 and DIN 6271. Prime Power Ratings: Prime power ratings assume no or unreliable utility power. For varying loads the generator set has unlimited operating hours. A 10% overload capacity is available for any 1 hour in a 12 hour continuous running period. Ratings are in accordance with ISO-3046/1 and DIN 6271. Consult Himoina for limited running time and base load ratings. Himoina reserves the right to change the design or specifications without notice and without any obligation or liability whatsoever. DERATION GUIDELINES: Altitude: Derate 1.3% per 100 m (328 ft) elevation above 1000 m (3280 ft). Temperature: Derate 1.0% per 10°C (18°F) temperature above 40°C (104°F).

HIPOWER CEM6 Auto Start Digital Controller



CONTROLLER DISPLAY :

1. Voltage between each Phase & Neutral
2. Voltage between Phases
3. Current (amps) on each Phase
4. Frequency
5. Active, Aparent & Reactive Power
6. Power Factor
7. Instant Power (Kwh) and Accumulative power (day, month & year)
8. Fuel reserve
9. Oil pressure, coolant temperature
10. Battery voltage, battery charging alternator voltage
11. Engine Speed
12. Hours running

ENGINE ALARMS :

1. High coolant temperature
2. Low oil pressure
3. Emergency stop

4. Battery charging alternator failure
5. Low coolant level
6. Low fuel level
7. Over speed
8. Under speed
9. Battery low voltage

GENERATOR ALARMS :

1. Over-load
2. Unbalanced voltage
3. Over-voltage
4. Under-voltage
5. Over-frequency
6. Under-frequency
7. Short-circuit
8. Inverse Power
9. Incorrect phase sequence

Distributor:

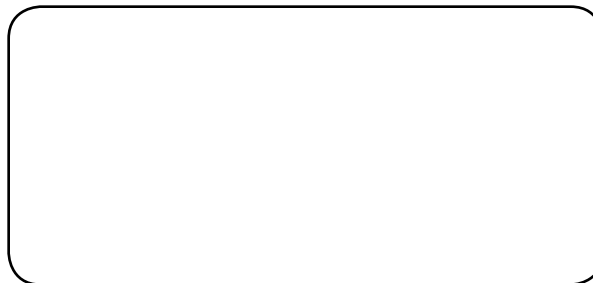

MEMBER

